

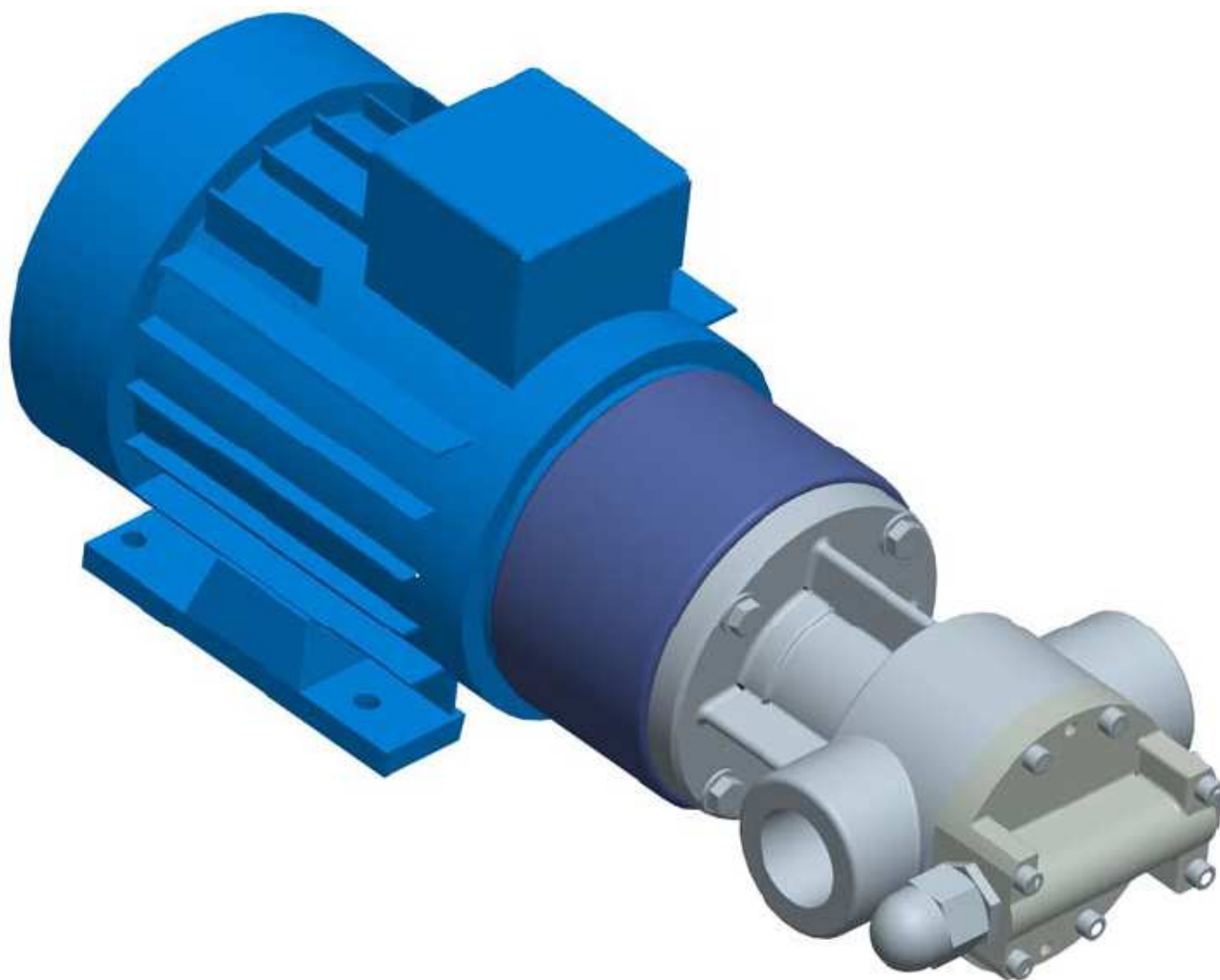

Instruction manual *MP 40 to 60*



Index

INTRODUCTION	3
WARRANTY EXCLUSIVE TECHNOLOGY	
SAFETY	6
ICONS USED	6
WORK CONDITIONS	6
SAFETY INSTRUCTIONS	7
TRANSPORTATION AND STORAGE	9
TRANSPORTATION	9
STORAGE	9
HANDLING	9
EXTENDED STOP	9
ASSEMBLING AND INSTALLATION	10
GROUP DEPLOYMENT	1
ENGINE PLUGGING	10
PIPE LINE INSTALLATION	10
COMMISSIONING	11
SUPPORT AND MAINTENANCE	12
WARNINGS	12
MOTORPUMP DISMANTLING	13
MECHANICAL SEAL DISMANTLING	14
PUMP DISMANTLING	15
BY-PASS DISMANTLING AND CONTROL	16
BY-PASS ASSEMBLING	16
NOMENCLATURE	17
TROUBLE SHOOTING CHART	16

INTRODUCTION

MUST BE READ IMPERATIVELY AND KEPT PRECIOUSLY

POMPES POLLARD has the right to modify this documentation. For further information, please contact our company.

Warranty

Warranty is void in the following circumstances: installation, storage outside vendor facility, or material installation not fitting its intended use, not according to vendor instructions or the rules, deterioration or accident as a result of negligence, lack of supervision or maintenance, modification of functioning conditions.

Warranty is also void in the case of interference, repair or dismantle of the material by the buyer or by a third party without the vendor's approval.

Exclusive Technology

Developed in the mid 40's, the "CMtec" technology allowed to design a pump capable of providing the advantages of the gear pump and the vane pump in a single pump.

Today, more than 60 years after selling its first pump, POMPES POLLARD SA has built its reputation for reliability and performance on this innovation.

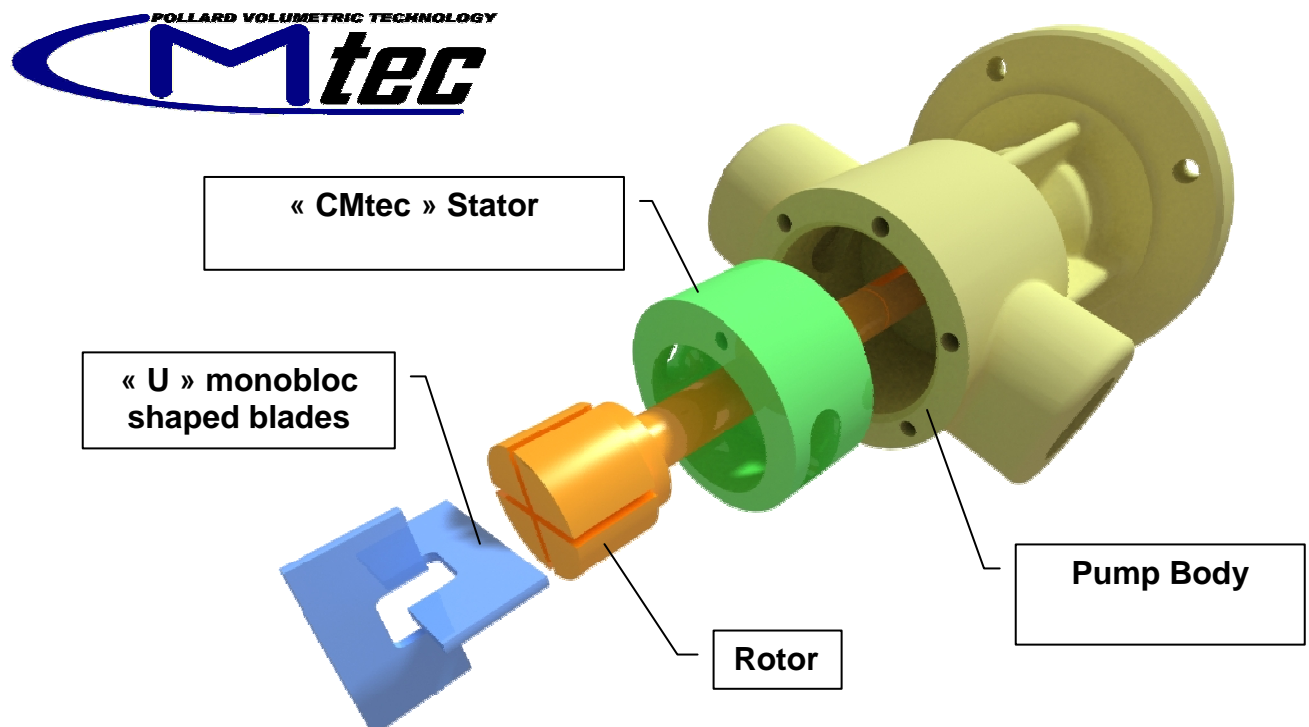

CM tec = Curved stator and Monoblock blades technology

CM tec concept :

Unlike most of the other types of pump, the stator bore is not cylindrical but of special shape, calculated by a mathematical equation.

The gear train is replaced by two rigid U-shaped blades.

Main advantages of CM tec technology:

- ***High reliability.***
- ***Characteristic ability to handle viscous fluid.***
- ***Volumetric pumping regardless of pump rotation speed and fluid viscosity.***
- ***Fluid flow direction independent of spindle rotation direction***
(For Reverse Plus pumps)
- ***Powerful suction.***
- ***Security By-pass included to provide pipe line protection.***
- ***Technical very simple.***
- ***Simple and fast maintenance.***



MP40 - MP60

Cubic displacement per rotation cm ³	40	60
speed rotation range in RPM	0 - 1800	
fluid viscosity range in cSt	1 - 20 000	
Pump vacuum in Bars	- 0,7	
Standard operating pressure in Bar	jusqu'à 10	
Standard operating temperature in °C	-20 / +180	
Body and stator materials	cast iron	
Shaft and blades materials	special steel	
Built in By pass	optional	
Maximal size of soft particles	200 microns	
Maximal size of hard particles	8 mm	
Seal type	mechanical	
Electric engine type in Kw	1,1Kw (MP40)	1,5Kw (MP60)



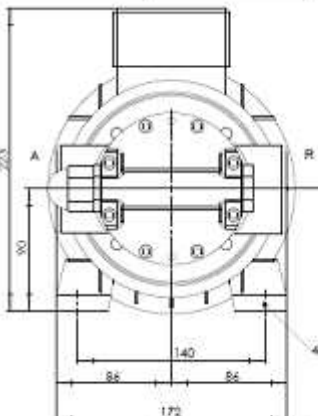

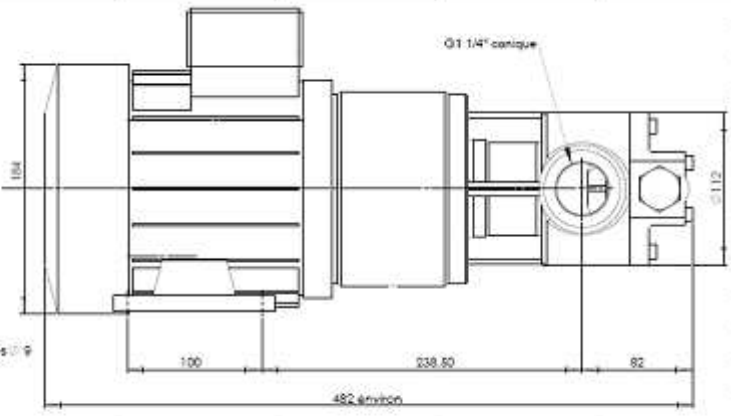

Flow calculation : The curves are for MP60 pump (60cm³ by turn) for MP40 it is necessary to divide by 1,5 (flow is proportional to the cubic capacity of the pump).

MP60 for 5 centistocks fluids

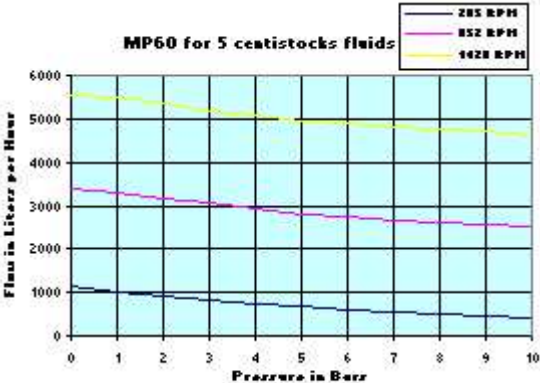

MP60 for 500 centistocks fluids

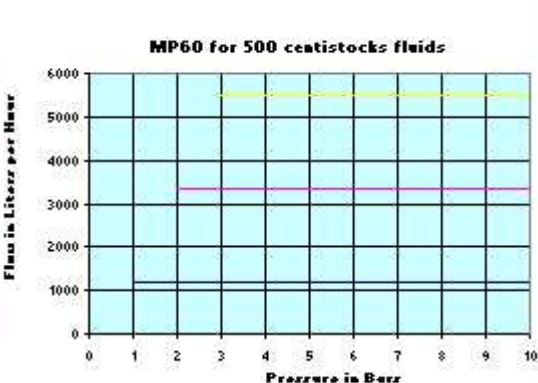

MP60 for 5000 centistocks fluids

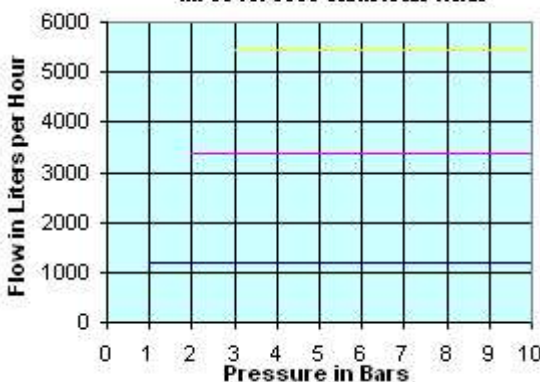



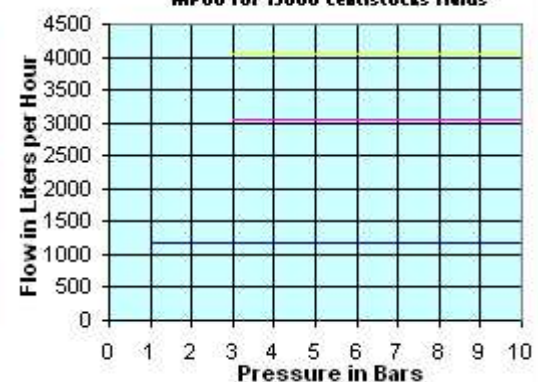





MP60 for 15000 centistocks fluids



SAFETY

Icons used



	Danger		Hand protection is needed
	Electrical danger		Face protection is needed
	Don't touch		Body protection is needed
	Corrosive substances		
	Stumble risk		
	Explosion risk		







Work conditions

We remind you that you must brief your personnel on the following:

- utilisation and maintenance conditions of the material
- additional instructions regarding the material (if needed)
- way to act upon predictable abnormal
- additional safety information resulting from utilisation experience which may decrease the risk of accidents

Safety instructions

	<ul style="list-style-type: none"> • This pump must not be run dry. Dry running will create friction heat which will damage the pump. • The body pump, the piping and junction areas are under internal pressure. One must never take off any security or protection, or unscrew any bolts, because it may induce damage to goods or persons. • Insufficient control and maintenance may result in accidents to goods and persons, especially when toxic or dangerous liquids are being pumped. • Using the pump in an environment demanding a certain level of protection or an engine and electrically superior components is forbidden. Please use components meeting the environments security standard. • When a pump is bought without an engine, the coupling with the engine must respect the safety standards, providing appropriate protections for future couplings, transmission belts, ... • Before proceeding to any dismantlement of the pump (in case of inspection, cleaning, maintenance, etc.), one must : <ul style="list-style-type: none"> ○ Shut down the engine and unplug the electric wiring. ○ Close the valves of the aspiration and evacuation system as to avoid any risk of flooding. ○ Use appropriate protection for hands and face if the pump contains dangerous liquids (acids, solvents, ...) • An appropriate cooling ventilation and sufficient maintenance space is needed when installing the pump. • The motor pump has been designed so that during its functioning, the user may not interact with the turning elements.
	<ul style="list-style-type: none"> • Electrical components are under high voltage. • Operations on the electric parts have to be carried out by skilled personnel, according to technical directions and law, on authorization of the responsible installer.

 	<ul style="list-style-type: none"> The motor pump has been designed so that during its functioning, the user may not interact with the turning elements. The trundle must never be removed while the pump is working. The pump must never be started without this trundle. If the surface temperature of the system or parts of the system exceeds 60°C, these areas must be marked with warning text reading "Hot surface" to avoid burns.  <ul style="list-style-type: none"> Always wear suitable safety clothing when handling the pump. 
	<ul style="list-style-type: none"> The trundle is not to be used as a step or a support.
	<ul style="list-style-type: none"> The group equipped with an IP 55 electrical engine is never to be used in a classified area. The pump must always be used in areas fitting the engine protection level (check with the governmental agency responsible for such precautions). Improper installation can cause fatal injuries.

TRANSPORTATION AND STORAGE

Transportation

When receiving the pump, please check the state of the container.

If you observe obvious damage, please proceed in the following manner:

- Receive the product and mention the observed defaults on the delivering papers.
- Photograph the observed damage
- Inform the transporter by registered letter with acknowledgment of receipt, joining the pictures taken earlier.

Storage

A pump which is not installed immediately should be stored in a cool and dark room. The storage should not exceed 2 years. If the pump has been out of operation for a longer period of time, the vanes should be greased before use to receive optimal suction ability.

Handling

The motor pump dimension does not need special handling procedures. However, if the group exceeds 20kg, a lifting equipment is needed.

Extended stop

When stopping the pump for a longer time, empty the pump completely and wash it thoroughly in order to avoid the formation of scales and/or encrustations.

This will ensure durability of the seal and of the pump itself.

It is the user's responsibility to ensure that the washing liquids are compatible with the process liquid and the pump.

For CMtech pump use water with soap. If the pump has been out of operation for a longer period of time, the vanes should be greased before use to receive optimal suction ability.

Warning: Before using the pump for different liquids than those specified upon buying, please verify that the joints and the mechanical seal material are compatible with the new product (please contact the company if otherwise).

ASSEMBLING AND INSTALLATION



Please read imperatively Safety chapter

Group deployment

The pump and its engine must not undergo any constraints (ex.: heavy pipes supported by the pump).

Do not remove the plugs from the orifices of the junctions unless when installing the pipes, this is to avoid the access of any foreign body to the interior of the pump.

Engine plugging



The wiring must be done by qualified personnel.

Cables and stuffing box must be of compatible diameter.

Electrical protections must be provided according to the standard.

Using a phase indicator ahead of the section switch allows to identify the colours of the wires and the junctions which will permit the engine to turn in the right way. One must imperatively respect the rotation direction, indicated on the pump and the trundle, to avoid deterioration of the mechanical seal and by-pass.

Pipe line installation

Always clean the piping before installing it. Remove the welding chips, flashes, carbon deposits and rust particles, in the case of rigid pipes.

Avoid the formation of air pockets in the alimentation pipes by using a steady slope. Motor pumps can be installed in any position, however engines are designed for horizontal use (if otherwise please contact the company).

The hydraulic junctions should be made with flexible and rotating junctions. Their interior diameter must be compatible with the pump flow, the viscosity and the pressure of the product being pumped (to avoid cavitations and over pressure).

On the aspiration side, install a straight pipe of 0.6m long without diameter variation (flow tranquilisation area).

On the lift of the pump, install a nonreturn valve.

These junctions must be done without constraints or charges to the pump. Check that the joints or seals do not run over pipes.

IMPORTANT: we advise you to use supervising equipment on the lift of the pump: flow control, pressure indicator, etc. to be able to avoid an unexpected lack of lubricant.

WARNING: The pump must not undergo water hammer.
If the circuit is provided with a fast or ultra rapid closing valve (less than a second), use an anti water hammer system on the aspiration pipe.

Generally, the pump is equipped with a security by-pass set to 5 bars full flow (this setting may be modified on demand). This by-pass must never be used as a pressure flow controller.

Commissioning

	<ul style="list-style-type: none">• Before starting the pump, make sure that nobody could be hurt by this operation.• Before commissioning, verify the seal of the pipes.
---	--

SUPPORT AND MAINTENANCE



Output spindle seal must be assured by lip seals or mechanical seals made from Nitril or Viton elastomer. One must verify that the pumped product is compatible with these materials, if you have any doubts please contact the producer or our society.

After about 1500 hours of functioning, or after maximum 2 years, dismantle the mechanical seal and change it.

The engine is equipped with bearings lubricated for life.

While the pump is running, supervise the rotation speed and the pressure at the lift of the pump. Make sure that the pump turns regularly without jerks or strange noises.

Warnings

	<ul style="list-style-type: none">• Any error in assembling or dismantling may result in the pump malfunctioning.• POMPE POLLARD is not responsible for the accidents or damage resulting from the lack of respect of these rules.• Never work on the pump while it is running.• Assembling and dismantling must only be done by experienced personnel who have the necessary hydraulic knowledge. These personnel must always wear appropriate protection equipment. 
---	--

Please work in a clean environment. Keep all the fragile parts preciously in their original packaging. The spare parts must be according to the technical specifications of the producer, which is always guaranteed for original spare parts.

Please check that none of the parts have been damaged during the transportation.

While using joints, make sure that you do not damage them by passing over sharp edges, screwing, etc. Make sure that they are not bent in their slots when being installed.

Motor pump dismantling

- Unscrew the 4 screws H M8 et washers M8 (rep. VIS0059 and RON0004)
- Remove the pump (rep. POMPE)
- Remove the trundle (rep. SOC0011)
- Dismantle the coupling (rep. ACC0013) on the pump side : 2 screws SHC M5x6, 1 wedge

NOTE: It is useless to dismantle the coupling on the engine side.

Motor pump reassembling should be made in the opposite order.

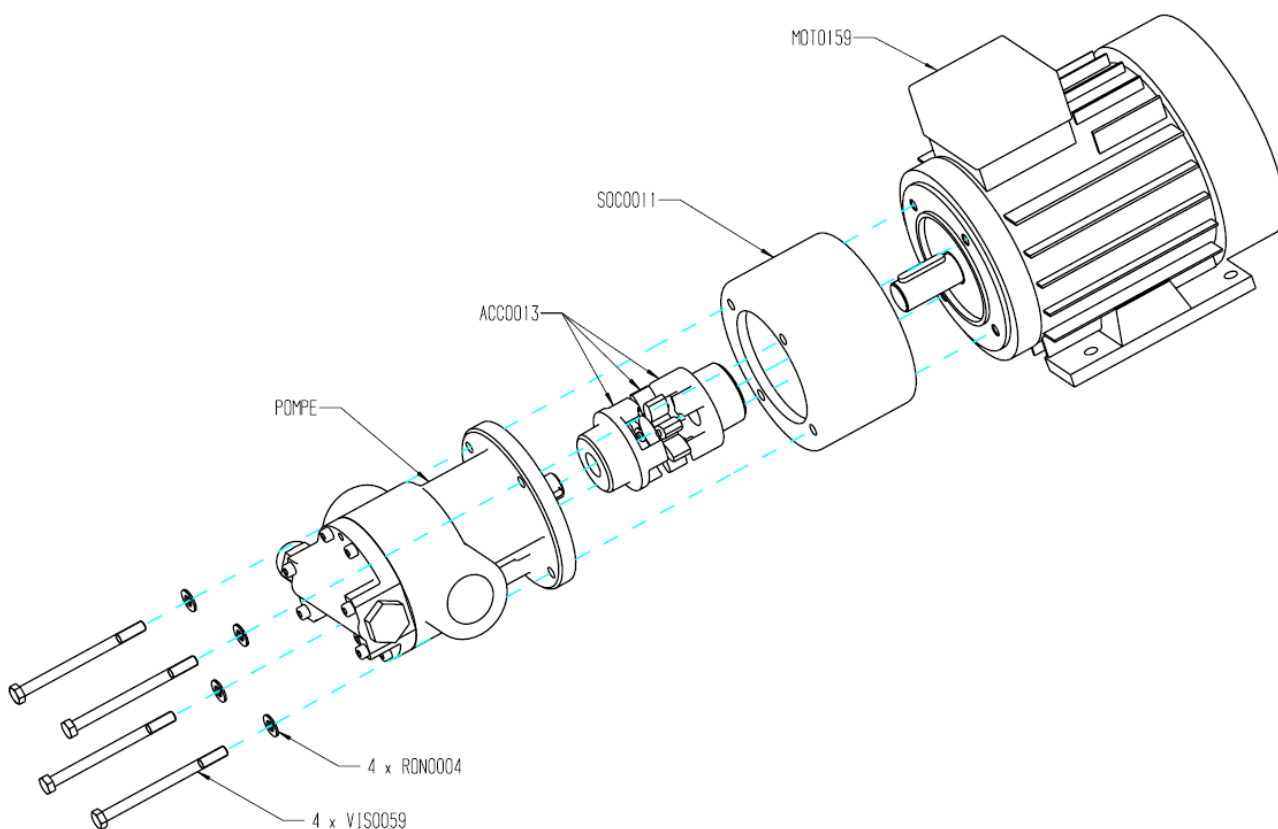

Mechanical seal dismantling

- At first realize the *Motor pump dismantling* operation (see above)
- Remove the wedge (rep. CLV0004)
- Remove the circlip for bores (rep. CIR0007)
- Remove the mechanical seal (rep. GAR0006) and replace it when reassembling
- Remove the support washer (rep. RON0003)

Mechanical seal reassembling should be made in the opposite order.

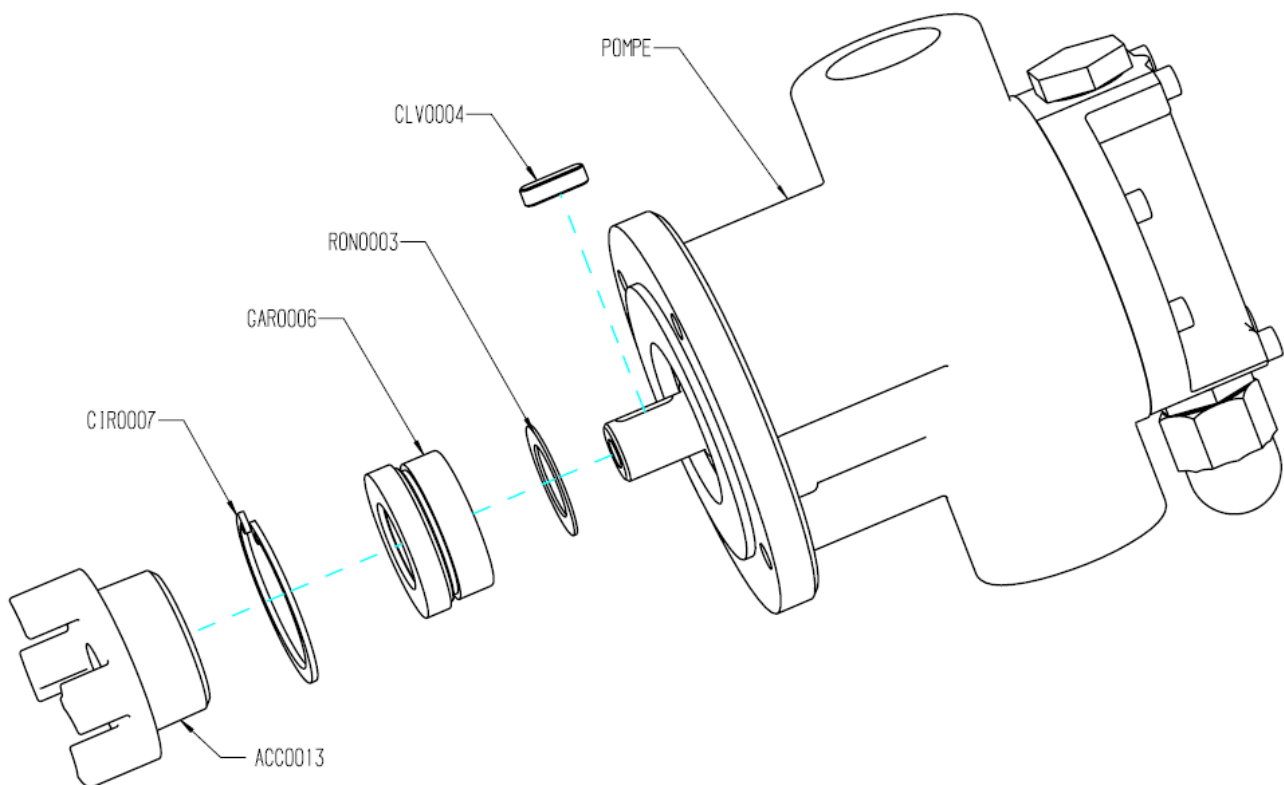

Pump dismantling

- At first realize the *Mechanical seal dismantling* operation (see above)
- Unscrew the 4 screws CHC M6 (rep. VIS0015) and the 4 screws CHC M6 (rep. VIS0016)
- Use 2 of these screws in the 2 holes M6 (rep. 2 x Trous M6) of the cap (rep. CHA0016) to remove it correctly.

IMPORTANT: While dismantling the cap, make sure you have recovered the index hand (rep. AIG0005) which assures the stator (rep. STA0051) positioning with the cap (rep. CHA0016).

- Remove the O-ring seal (rep. JOT0010)
- Remove the 2 blades (rep. PAL0006) and replace it when reassembling
- Remove the stator (rep. STA0051) and replace it
- Remove the circlip for shafts (rep. CIR0006)
- Remove the rotor (rep. ROT0033) and replace it too
- Remove the first bearing (rep. ROU0002)
- Remove the second bearing (rep. ROU0001)
- Remove the crosspiece (rep. ENR0001)

Pump reassembling should be made in the opposite order.

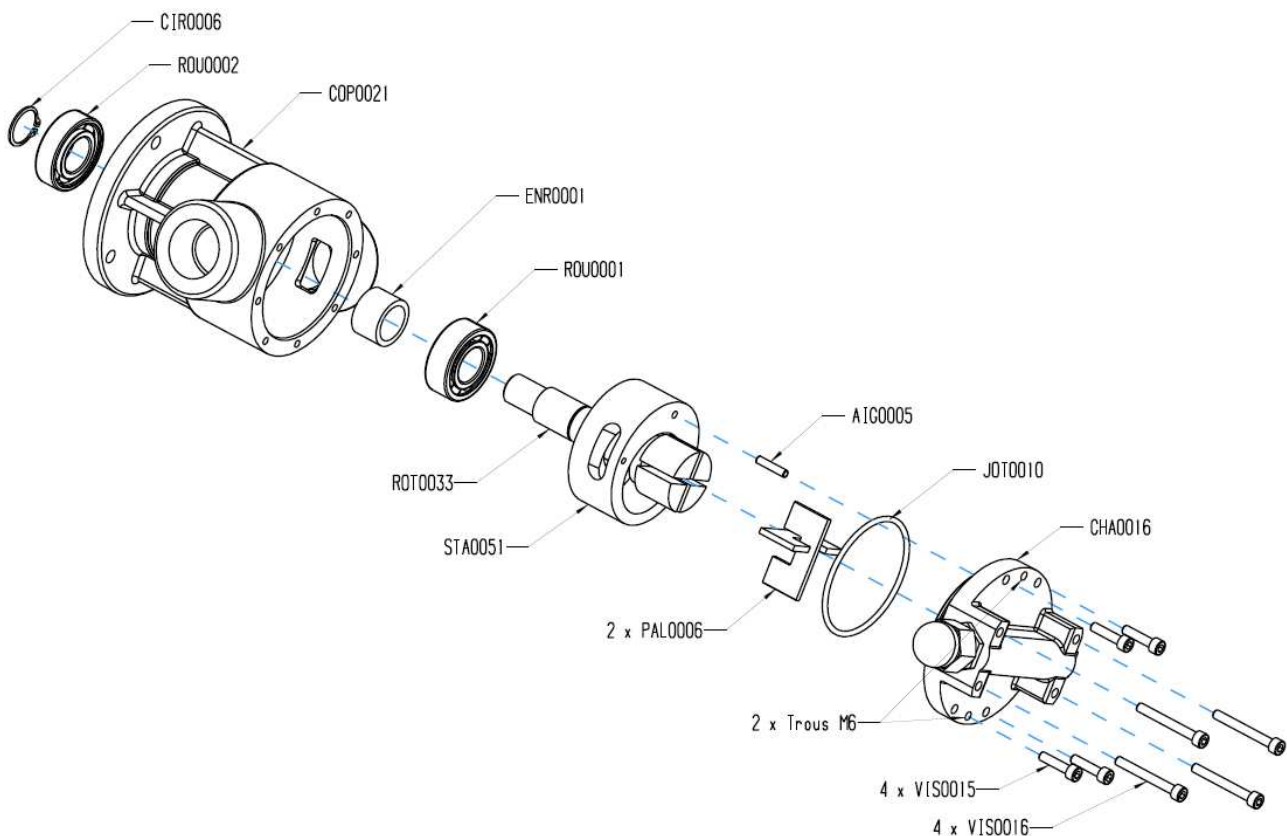

By-pass dismantling and control

By-pass calibration has already been done by means of the VIS0014. While dismantling it, it is important to keep track of the number of turns to unscrew in order to reassemble it correctly.

- Unscrew the cap nut (rep. ECB0002)
- Remove its copper joint (rep. JOC0005)
- Unscrew the counter nut (rep. COE0002)
- Remove its copper joint (rep. JOC0005)
- Unscrew the regulating screw (rep. VIS0014) and keep track of the number of turns to unscrew
- Remove the spring (rep. RES0011)
- Unscrew the plug (rep. BOU0002)
- Remove its copper joint (rep. JOC0005)
- Remove the slide valve (rep. TIR0002)

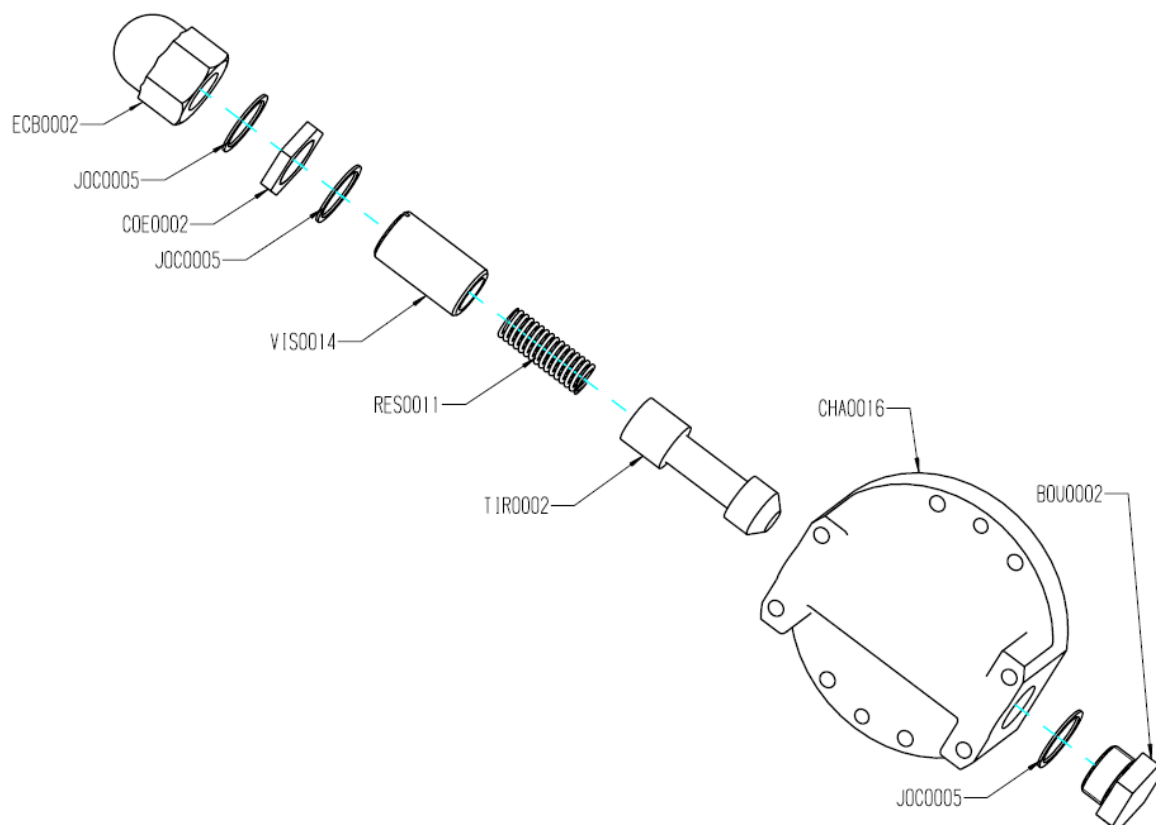

By-pass assembling

It should be done in the opposite order:

Check the good state of the flap and its seat. Screw the VIS0014 with the same number of turns used while dismantling it.

This by-pass is designed as a security, it must be used only in case of an incident or a cold start, but it must never be used as a flow regulator.

If you notice any deterioration of the flap or its seat, one must control the instant pressure, change the flap and reset the seat.

Nomenclature

Component	Naming	Qt
STAxxxx *	SHAPED STATOR	1
JOTxxxx *	O-RING SEAL 82.14X3.53	1
GARxxxx *	MECHANICAL SEAL DIA 25	1
RES0011	BY-PASS SPRING 60700-5	1
SOC0011	TRUNDLE MP40	1
ACC0013	ROTEX COUPLING R28 20X24	1
VIS0059	SCREW ZN H 8X110	4
RON0004	WASHER DIA8 ZN	4
MOTxxxx *	ENGINE	1
COP0021	SHAPED PUMP BODY P40 150	1
CHA0016	BY-PASS CAP 60304	1
ROT0033	SHAPED ROTOR P40	1
PAL0006	SHAPED BLADE 5829	2
VIS0014	BY-PASS REGULATING SCREW 60602	1
TIR0002	BY-PASS SLIDE VALVE DIA20	1
COE0002	COUNTER NUT P40	1
ECB0002	CAP NUT P40	1
BOU0002	BY-PASS PLUG 60601	1
JOC0005	COPPER JOINT 22.2X27X1	3
ROU0001	BEARING 4205	1
ROU0002	BEARING 6205	1
ENR0001	CROSSPIECE 60801	1
RON0003	SUPPORT WASHER 25X38X1	1
CIR0006	CIRCLIP FOR SHAFTS E25	1
CIR0007	CIRCLIP FOR BORES I55	1
AIG0005	NEEDLE 5 X23.8 BR	1
CLV0004	WEDGE BA 6X6X20	1
VIS0015	SCREW CHC 6X25	4
VIS0016	SCREW CHC 6X50	4

N.B.: * For any part replacement, please contact our company.

TROUBLE SHOOTING CHART

		Failures											
		The pump does not run	The delivery is not sufficient	The pressure is not sufficient	The pump stops priming	Power absorption too higher	Leakages from the mechanical seal	Short life of the mechanical seal	Failure of the mechanical seal	Anomalous vibrations and/or noise	Short life of bearings	causes	corrections
												Air entering from the mechanical seal.	Replace the mechanical seal or arrange a solution with a vacuum spring in case of vacuum suction operation.
												Obstructions present along suction pipes or valves closed along pipes.	Verify and remove all foreign matters from pipes and finally verify valves status (if closed, open them).
												NPSH available in the plant is lower than NPSH needed by the pump.	Reduce the friction loss or adjust the pump at a lower delivery point.
												Plant friction losses higher than pump performances.	Reduce friction losses or replace the pump with a most suitable one for requested performances
												Opposite direction of rotation or too low velocity (in case of a pump operated by an inverter).	Restore the correct sense of rotation, increase the motor speed.
												Worn mechanical seals.	Replace worn parts.
												Pumped fluid too viscous.	Verify the pump size.
												Presence of too much gas in the fluid	Fit an air relief valve.
												Plant friction losses lower than foreseen ones.	Increase friction losses or adjust the pump at a higher working point.
												Fluid specific gravity higher than foreseen one.	Increase the installed motor power.
												Rotation speed too high (when pump is controlled by an inverter).	Reduce the velocity.
												Misalignment of pump-motor or distorted shaft.	Restore the correct alignment between pump and motor; replace the shaft with a new one.
												Worn bearings of pump or motor.	Replace the bearings.
												Electric misconnection.	Modify the electric connection by strictly following ratings written on the motorplate according to the available voltage.
												Voltage not suitable for the installed motor.	Replace the motor with one having a suitable voltage.
												Mechanical seal worn	Replace the mechanical seal.
												Pump fluid or temperature not suitable for the assembled mechanical seal or its parts.	Verify the mechanical seal selection. Increase washing cycles and don't leave the product staying inside the pump for a long time.
												Non-cleaning when using fluids which tend to crystallize.	Assemble the mechanical seal again with attention.
												Incorrect assembly of the mechanical seal.	Arrange the proper dry-running protection in order to avoid the problem.
												Dry operation of the pump.	Restore normal assembly conditions by replacing the worn pieces.
												Oscillations on the shaft due to a too high assembly allowance, worn bearings, etc.	Verify the mechanical seal selection.
												Suspended solid parts in the fluid	Increase gradually the fluid temperature by avoiding instantaneous thermic amplitudes, prevent the pump from dry-running.
												Too high temperature or thermic shock.	Verify and adjust anchorage of the involved parts.
												Pump and/or pipes are not properly anchored.	Replace worn parts.
												Water seepage due to worn oil retainers.	