



# SYRUP TRANSFER UNIT

## Application

Transfer of syrup up to 10,000 cSt

## Operating limits

Pumping technology	Pollard monobloc vane pump
Capacity (cc)	60,3
Speed (rpm)	240
Flowrate (m <sup>3</sup> /h)	0,9
Suction pressure (bar)	-0,5 max
Differential pressure max (bar)	9 max
Maximum fluid temperature (°C)	50
Maximum external temperature (°C)	40
Viscosity (cSt)	up to 20,000
Mechanic by pass (bar)	9

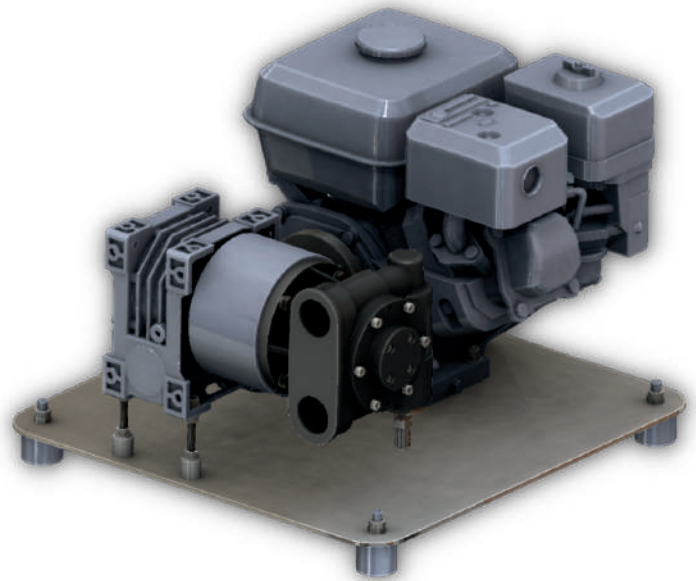

UT-SYRUP

## Materials

Body	Cast Iron
Shaft	Treated steel
Vanes	Treated steel
Frame	Stainless steel

## Dimensions

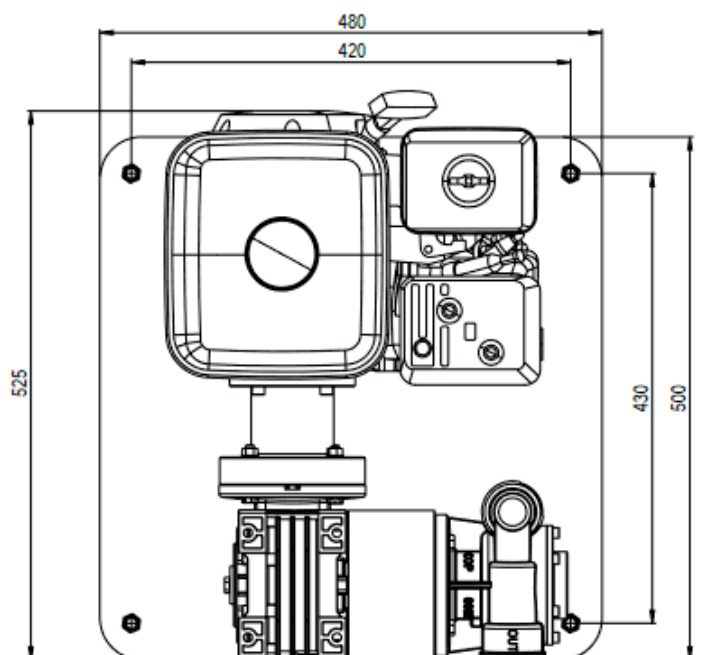
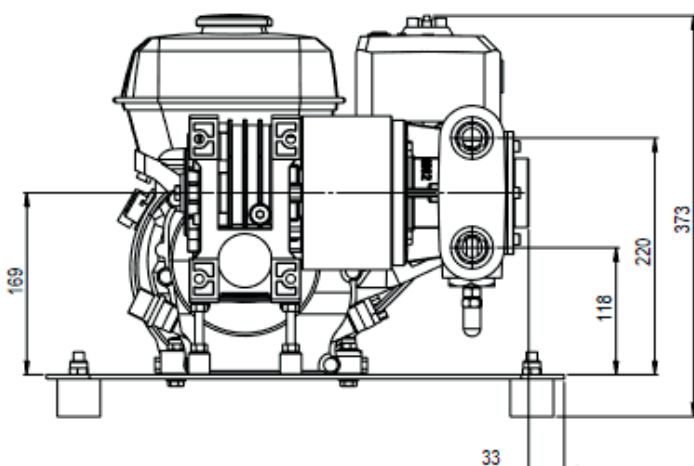
 In mm, weight 22 kg



**POMPES POLLARD**

189 avenue de Copenhague  
Parc d'Activités de Signés  
83870 Signés, FRANCE

T +33 (0)4 94 10 19 90  
contact@pompes-pollard.com  
[www.pompes-pollard.com](http://www.pompes-pollard.com)