



HONEY TRANSFER UNIT

Application

Bee keeping

Operating limits

Pumping technology	Pollard monobloc vane pump
Capacity (cc)	55
Speed (rpm)	200
Flowrate (m ³ /h)	0,66
Suction pressure (bar)	-0,3 max
Differential pressure max (bar)	3 max
Maximum fluid temperature (°C)	50
Maximum external temperature (°C)	40
Viscosity (cSt)	Up to 20,000
Pneumatic or mechanic by pass (bar)	No
Pump type	Reversible pump
Electric supply	Single-phased or tri-phased

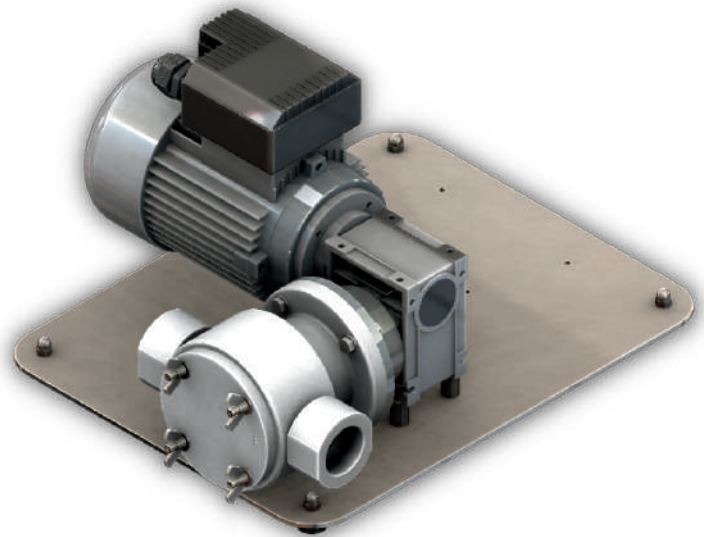

UT-HONEY

Materials

Body	FDA certified composite
Shaft	316 stainless steel
Vane	316 stainless steel
Frame	Stainless steel

Dimensions

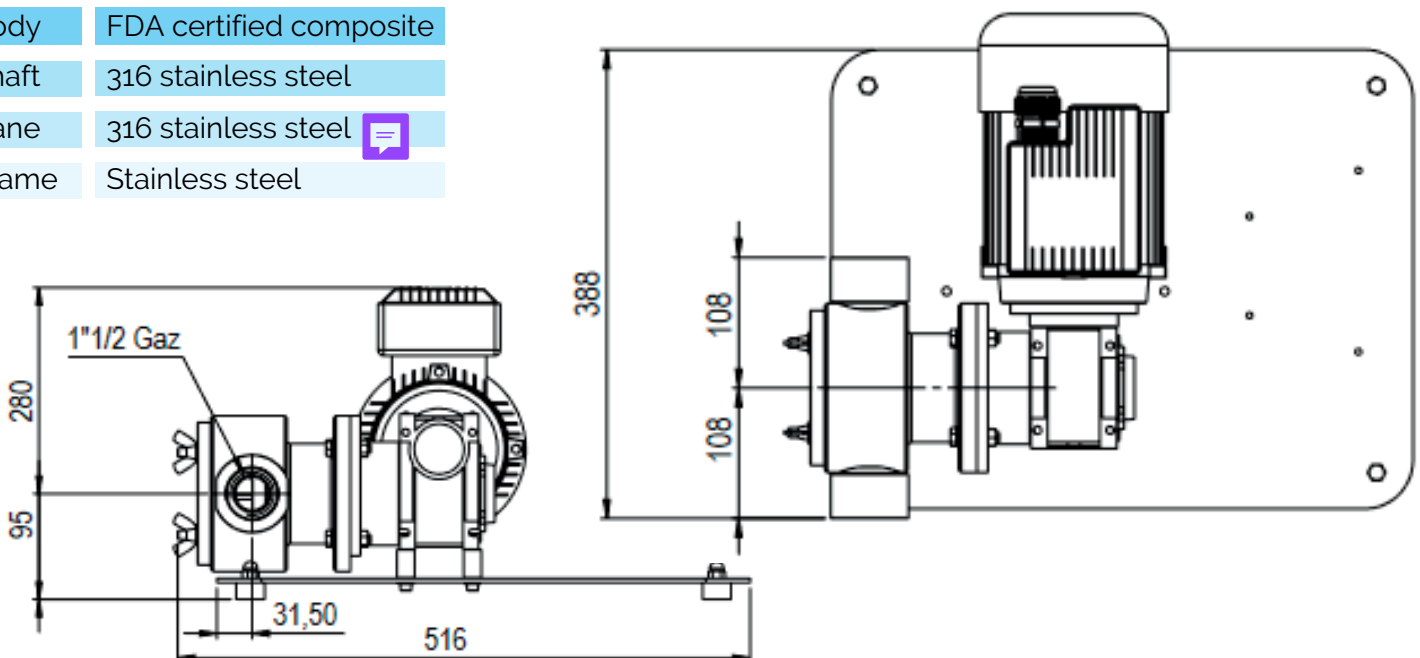
 In mm, weight 15 kg



POMPES POLLARD

189 avenue de Copenhague
Parc d'Activités de Signés
83870 Signés, FRANCE

T +33 (0)4 94 10 19 90
contact@pompes-pollard.com
www.pompes-pollard.com